



GEARENCH PETOL MACHINE TONGS



PETOL MACHINE TONGS provide positive grip in the upward motion and perfect ratcheting in the downward motion. Noncrushing and nonjamming action are features that make this tong outstanding. The MA16HS can be furnished with a 3-4 chain combination for higher torque requirements.

PETOL Machine Tongs						
CATALOG NO.	O.D.*	GRIPPING WIDTH	HANDLE LENGTH**	WEIGHT***	MAXIMUM WORKING LOAD	Nm MAXIMUM WORKING LOAD
MA15S	2" - 10"	4.00"	28"	37 lbs.	5,000 ft.-lbs.	6.775 Nm
MA155-16S	3" - 16"	5.00"	32"	54 lbs.	8,950 ft.-lbs.	12.127 Nm
MA16HS (2-2 Chain)	4" - 16"	5.25"	35"	85 lbs.	11,500 ft.-lbs.	15.582 Nm
MA16HS (3-4 Chain)	4" - 16"	5.25"	35"	85 lbs.	17,500 ft.-lbs.	23.712 Nm
	*Chain assemblies must be ordered separately. See chain guide.					
	**Call factory for torque arm lengths.					
	***Weights do not include chain.					

WARNING! Do Not Exceed Maximum Working Load. Overloading may result in injury or death. Always use a load cell or other calibrated indicating device to monitor the line pull on the tong to avoid overload. Read Safe Practices & Procedures Manual prior to operation. Follow OSHA, NSC, etc. standards, safe practices, and procedures.

GEARENCH PETOL MACHINE TONGS

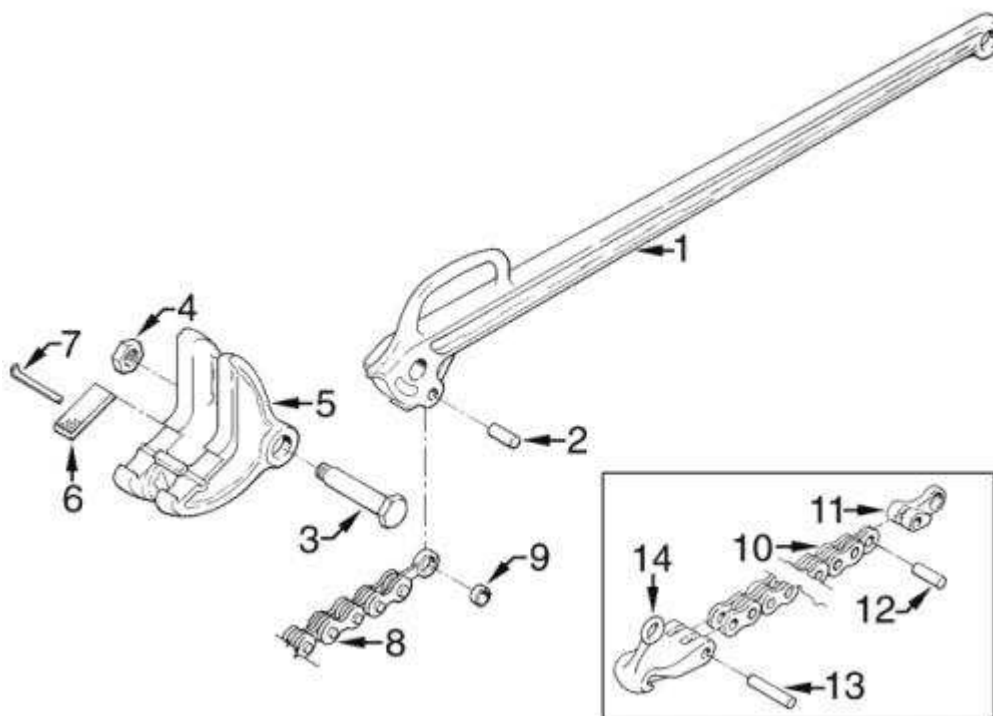

PETOL Machine Tong		
KEY NO	ITEM DESCRIPTION	NO. REQ'D.
1	HANDLE	1
2	MASTER LINK HANDLE PIN	1
3,4	JAW BOLT & NUT	1
5	JAW	1
6	INSERT	2
7	INSERT PIN	1
8	PETOL SPECIAL CHAIN W/MASTER LINK	1
9	MASTER LINK BUSHING	1
10	SPECIAL CHAIN ONLY	1
11	MASTER LINK	1
12	MASTER LINK CHAIN PIN	1
13	CHAIN HOOK PIN	1
14	CHAIN HOOK	1