

Data Sheet KTZ21.5-51

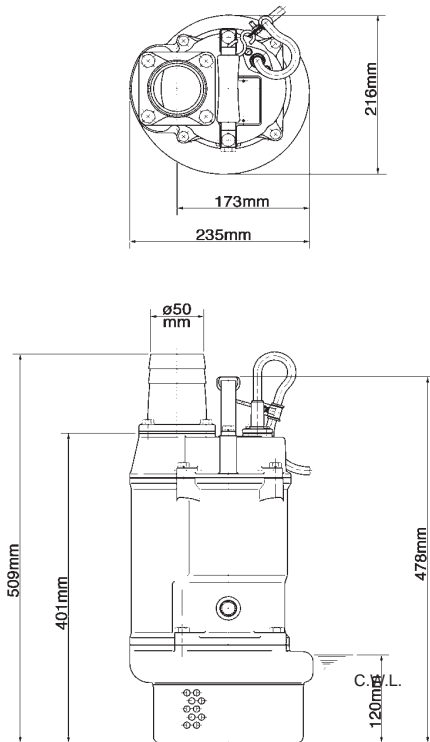

KTZ21.5-51 (A-10127-1)

C.W.L. = Continuous running water level

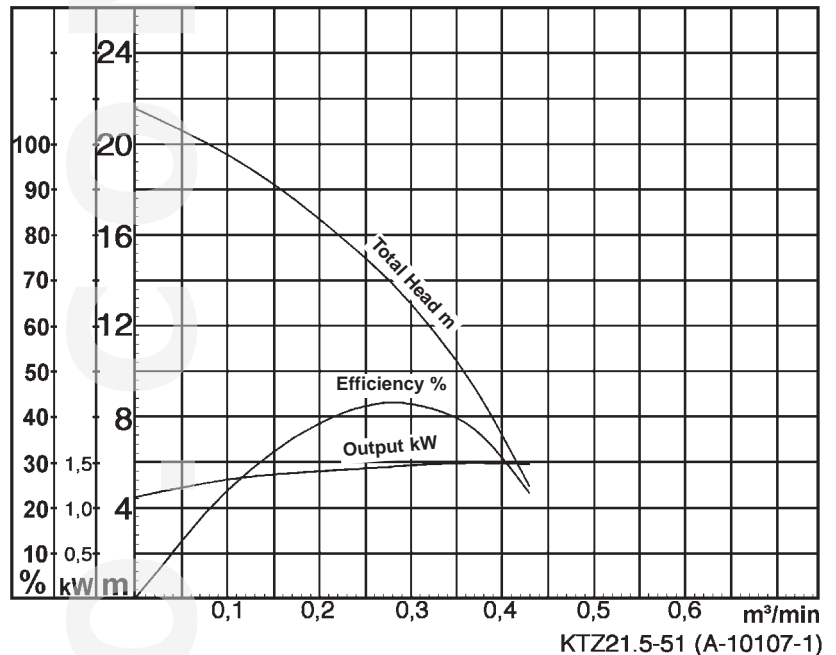

Classification

Electric submersible pump
 Protection class IP68
 Depth of submersion max. 50m
 Open type impeller
 Max. solid handling 8,5mm
 Suitable for spring water, rain water, ground water, sand carrying water

Electric Motor

Dry-type submersible induction motor,
 Insulation class F, 2 poles, 2840 r.p.m.
 Direct on line start
 Voltage: 400V, 50Hz, 3-phase
 Power input: 2,17kW
 Power output: 1,5kW
 Nominal current: 3,5A
 Start current: 22,0A

Electric Cable

20m H07RN-F 4Cx1,5mm²

Motor Protection

Circle thermal protector
 (snap-action bi-metal device)

Shaft Seal

Double mechanical seal in oil bath
 additional lubrication by oil lifting device
 Primary Seal:
 silicon carbide on silicon carbide
 Secondary Seal:
 silicon carbide on silicon carbide

Bearings

Shielded ball bearings, maintenance-free

Materials

Impeller:	Chromium iron casting
Casing:	FC200 (EN-GJL-200)
Suction Cover:	FCD500 (EN-GJS-500-7)
Motor frame:	FC150 (EN-GJL-150)
Shaft:	SUS420J2 (EN-X30Cr13)

Discharge Connection

2" (50mm) BS-Coupling (threaded flange)

Weight

30 kg (dry weight of the pump without cable)

Dupagro B.V.

Ooststeeg 102
 6708 AX Wageningen
 The Netherlands

Phone +31 (0) 317 840 197
info@dupagro.com
www.dupagro.com

Dimensional Drawing KTZ21.5-51

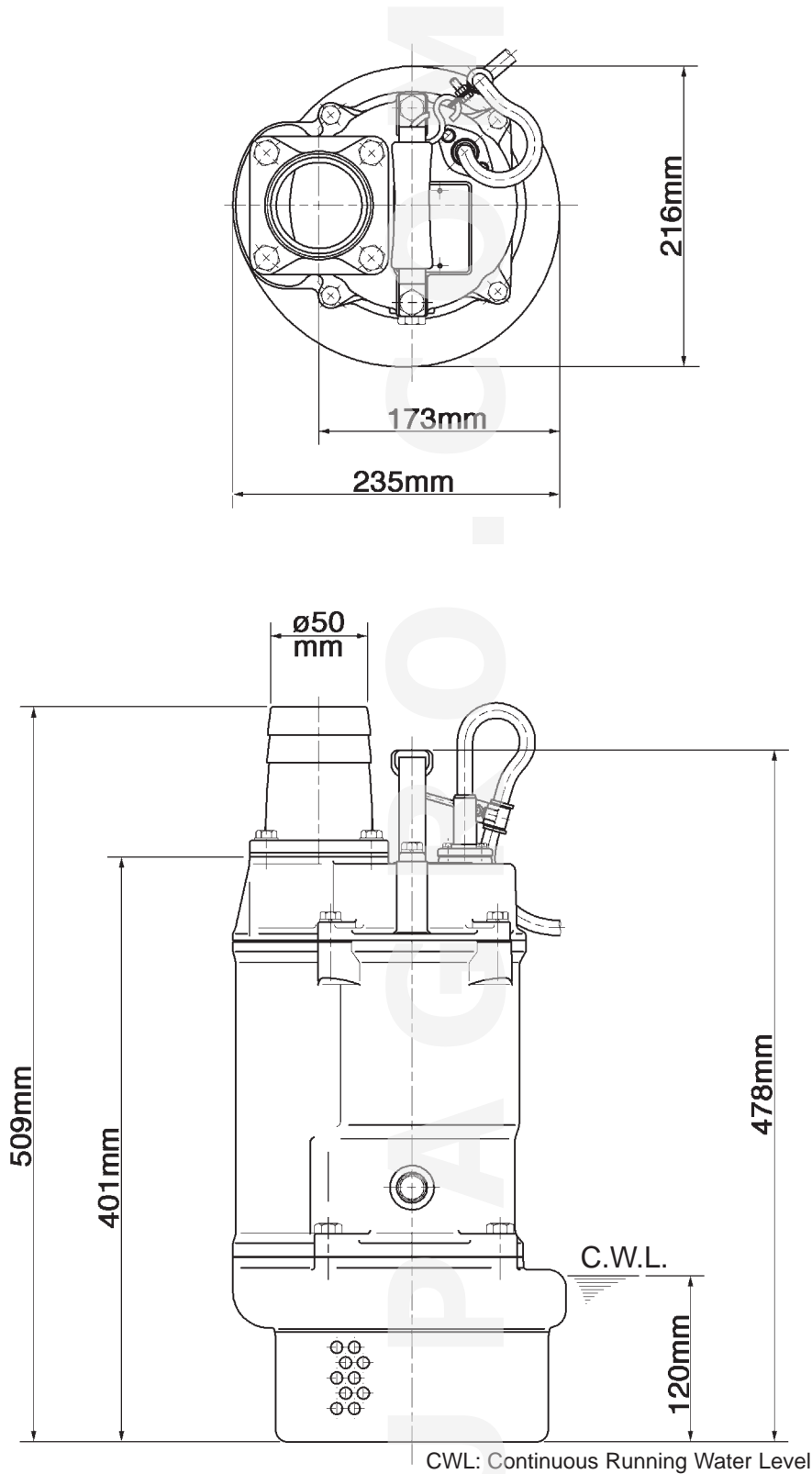

CWL: Continuous Running Water Level
KTZ21.5-51 (A-10127-1)

Sectional Drawing

KTZ21.5-51

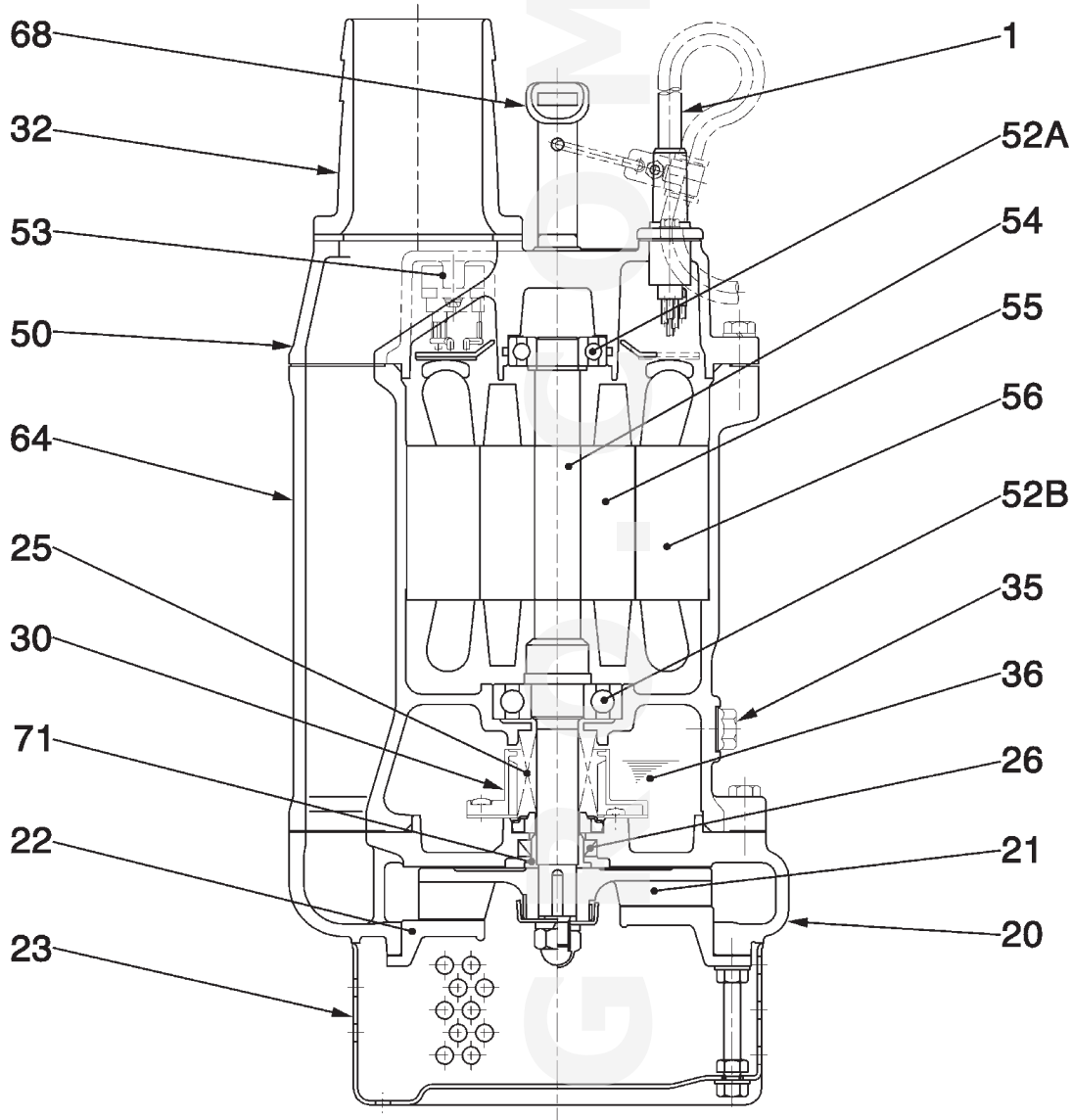
KTZ21.5-51 (A-1031-1)

No.	Description	Qty.	Remarks	No.	Description	Qty.	Remarks
1	Cabtyre Cable	1	H07RN-F	53	Motor Protector	1	
20	Pump Casing	1	FC200 (EN-GJL-200)	54	Shaft	1	SUS420J2 (EN-X30Cr13)
21	Impeller	1	Chromium Iron Casting HiCrFC	55	Rotor	1	
22	Suction Cover	1	FCD500 (EN-GJS-500-7)	56	Stator complete	1	
23	Strainer Stand	1	Steel Plate SPCC	64	Motor Frame	1	FC150 (EN-GJL-150)
25	Mechanical Seal	1	H-20T	68	Handle	1	Steel Plate SPCC + Rubber NBR
26	Oil Seal	1	DD25388	71	Shaft Sleeve	1	SUS304 (EN-X5CrNi18-10)
30	Oil Lifter	1	Plastic				
32	Hose Coupling	1	Aluminium Alloy Casting ADC12				
35	Oil Plug	1	SUS304 (EN-X5CrNi18-10)				
36	Lubricant		Turbine Oil (ISO VG32)				
50	Motor Bracket	1	FC150 (EN-GJL-150)				
52A	Upper Bearing	1	6204ZZC3				
52B	Lower Bearing	1	6305ZZC3				

Dupagro B.V.

 Ooststeeg 102
 6708 AX Wageningen
 The Netherlands

 Phone +31 (0) 317 840 197
info@dupagro.com
www.dupagro.com

Pump Performance Curve

KTZ21.5-51

Discharge Bore	50 mm
Total Head	15 m
Capacity	0,25 m ³ /min
Motor Output	1,50 kW
Motor Input	2,17 kW
Phase	3
Voltage	400 V
Frequency	50 Hz
Rated Current	3,5 A
Starting Current	22,0 A
Poles	2
Revolution	S.S. 2840 r.p.m.
Starting Method	direct on line
Insulation Class	F

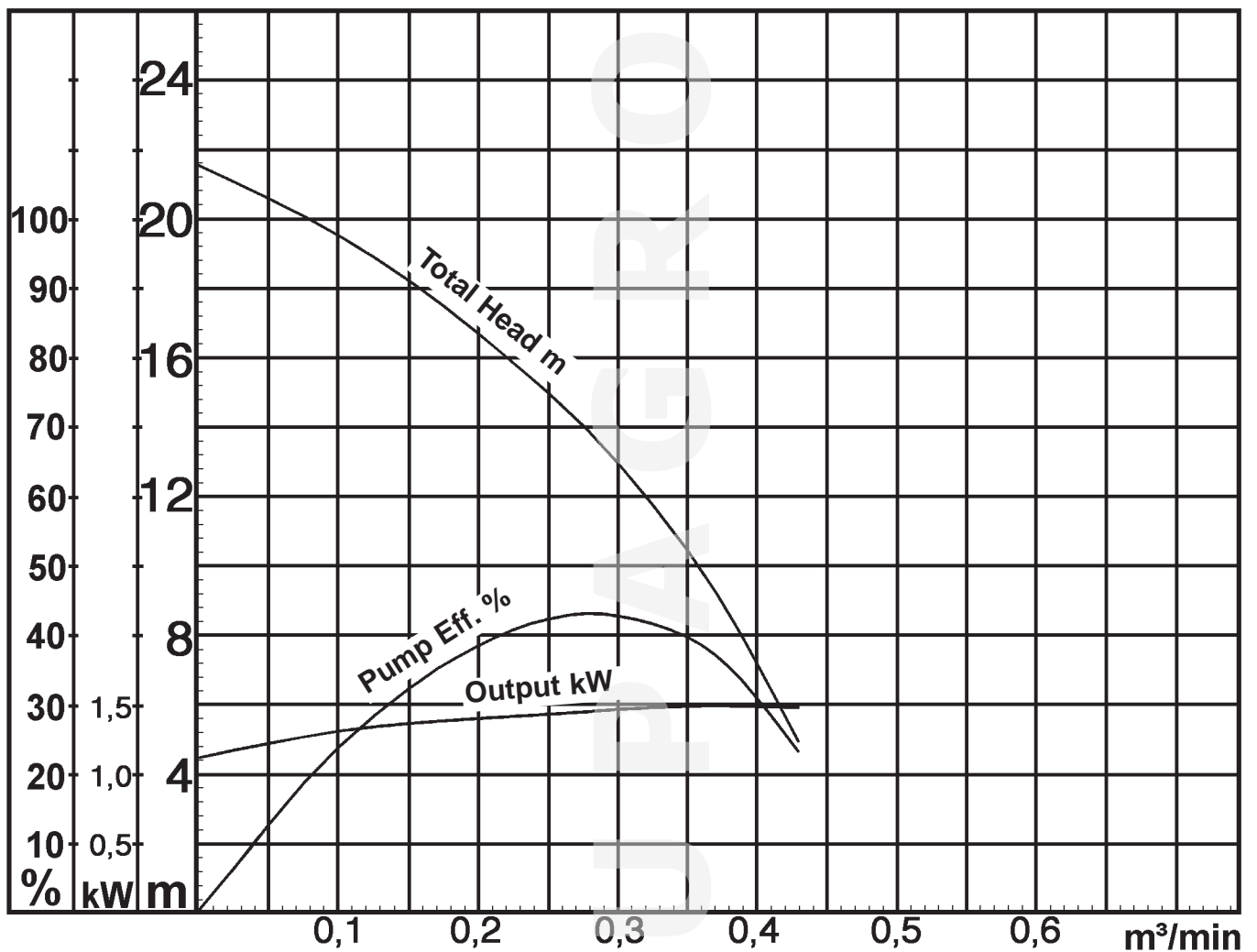

KTZ21.5-51 (A-10107-1)

KTZ21.5-51

2016-10-17 V.18 / 1.10.2015

KTZ21.5-51			
Item	Item no.	Description	Quant.
1	140-074-15	Hex.Bolt M10x20 SUS304 (EN X5CrNi18-10) Stainless Steel	2
2	068-000-17	Handle KTZ1.5/2.2-61(USA) SPC+ NBR	1
3	010-126-17	Cable Clip Rubber HS2 NBR	1
4	010-105-10	Cable Clip SB SPC	1
5	140-018-37	Hex.Bolt M5x15 SWRM	1
6	141-003-58	Hex.Nut M5 SWRM	1
7	140-427-17	Hex.Bolt (w/Plain Washer) M5x15 SUS304 (EN X5CrNi18-10)	2
8	003-190-10	Gland SUS316 (EN X5Cr-Ni-Mb17-12-2)	1
9	001-TEG-31	Cabtyre Cable Set (20m) H07RN-F4Cx1,5mm² with gland	1
9	M01-TEG-31	Cabtyre Cable Set (20m) NSSHÖU 4Cx1,5mm²	1
10	140-076-59	Hex.Bolt M10x30 SUS410 (EN X12Cr13) Stainless Steel	4
11	142-128-24	Plain Washer M10 Kaltgewalztes Blech	4
12	032-111-17	Hose Coupling 50mm(15H) ADC	1
12	032-434-19	Hose Coupling (for EUR)KTZ(BSPT-2) FC	1
13	121-181-17	Packing KT-15 NBR	1
14	140-488-16	Hex.Bolt (w/Spring Washer) M8x30 SUS304 (EN X5Cr18-10)	4
15	050-421-19	Motor Bracket FC	1
16	122-140-17	O-Ring G-145 NBR	1
17	053-471-13	Motor Protector 380-420V-50HZ 380-460V-60HZ KA311-DPWJ78 (T.C)	1
18	143-126-12	Pan Screw (w/Spring Washer/Plain Washer) M4x12 SWRM	2
19	009-292-11	Earth Terminal 1.25mmx140L	1
20	143-085-34	Pan Screw (w/Spring Washer) M4x6 C3604 (EN CuZn39Pb3)	1
21	142-389-12	Wave Washer #6204 SK-5	1
22	052-187-16	Bearing (w/O-ring) AC-6204ZC3	1
23	122-293-16	O-Ring 47x3.1 NBR	1
24	061-174-18	Slinger d20xd27x2t SPC	1
25	058-000-13	Lead Wire Protection Plate d61xd136x2t (Resin)	1
26	055-705-15	Rotor	1
27	147-017-11	Impeller Key 5x5x20l SUS	1
28	056-001-14	Stator 380/400/415V-50Hz(EUR)	1
29	052-108-13	Bearing 6305ZC3	1
30	121-507-13	Packing (Water Way, Upp.) KTZ21.5/32.2 NBR	1
31	064-000-10	Motor Frame (FC)	1
32	140-488-16	Hex.Bolt (w/Spring Washer) M8x30 SUS304 (EN X5Cr18-10)	4
33	121-246-11	Packing (Oil Plug) d10.3xd16x2t PE	1
34	035-000-01	Oil PlugM10x16(B=13) EN X5CrNi18-10	1
34	035-125-13	Oil Plug M10x20(B=13) SUS304 (EN X5CrNi18-10) Stainless Steel	1
35	025-243-17	Mechanical Seal H-20T SiC	1
36	143-070-10	Pan Screw M5x6 SWRM	2
37	030-144-13	Oil Lifter H-20(A)T Resin	1
38	143-070-10	Pan Screw M5x6 SWRM	4
39	030-154-16	Seal Stopper H-20T SPCC	1
40	122-139-13	O-Ring G-140 NBR	1
41	121-501-17	Packing (Water Way, Low.) KTZ21.5/22.2 NBR	1
42	020-001-01	Pump Casing KTZ21.5/32.2 FC	1
42	020-001-01	Pump Casing KTZ21.5/32.2 FC	1
43	026-105-19	Oil Seal TC-25388 NBR	1
43	026-105-19	Oil Seal TC-25388 NBR	1
44	071-314-13	Shaft Sleeve d20xd25x16l SUS304 (EN X5CrNi18-10) Stainless Steel	1
45	040-104-25	Impeller Shim d18.2xd29x0.3t SUS304 (EN X5CrNi18-10) Stainless Steel	1
46	021-554-12	Impeller (50HZ) 15H/50Hz HiCrFC	1
47	047-113-28	Impeller Thread Protect.Cover No.3A(13.5) SUS304 (EN X5Cr18-10)	1
48	142-165-10	Spring Washer M12 SUS304 (EN X5Cr18-10)	1
49	141-032-14	Hex.Cap Nut M12 SUS304	1
50	120-110-12	Packing (S.Cover) d150xd186x0.3t PE	1
51	022-000-52	Suction Cover KTZ21.5/22.5 (FCD)	1
51	022-000-52	Suction Cover KTZ21.5/22.5 (FCD)	1
52	142-127-23	Plain Washer M8 SPC	3
53	144-000-56	Stud Bolt M8x85(12/30) SUS410 (EN X12Cr13) Stainless Steel	3
54	023-472-11	Strainer Stand KTZ21.5/32.2 SPCC	1
55	142-127-23	Plain Washer M8 SPC	3
56	141-005-89	Hex.Nut M8 SWRM	3
	173-513-13	Packing & O-Ring Set	1
	##oilVG32	ml Turbine Oil ISO VG32	740

Dupagro B.V.

 Ooststeeg 102
 6708 AX Wageningen
 The Netherlands

 Phone +31 (0) 317 840 197
info@dupagro.com
www.dupagro.com

Exploded View KTZ21.5-51

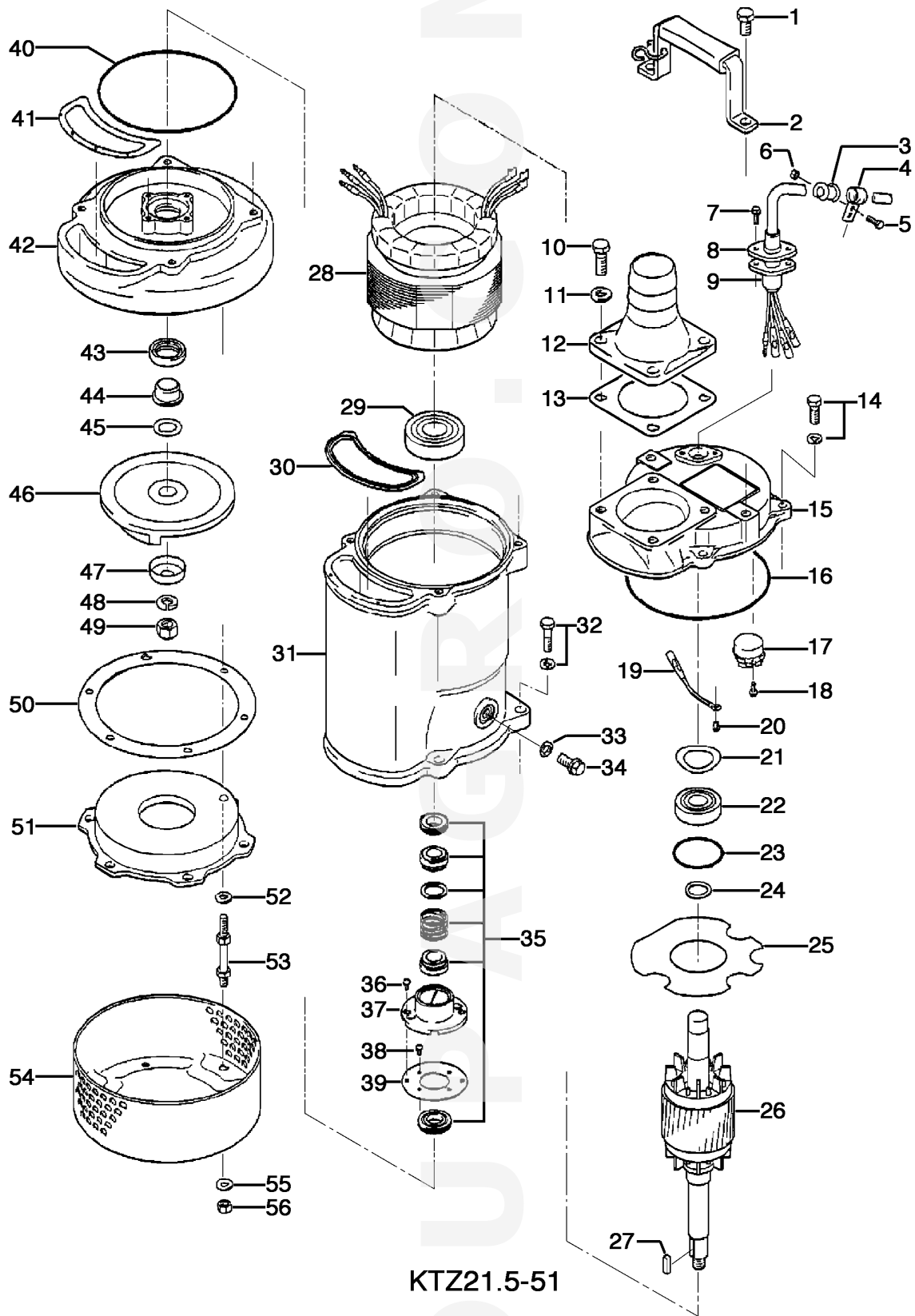

KTZ21.5-51

